

# TECHNICAL INFORMATION



PRODUCT

P 1 / 20

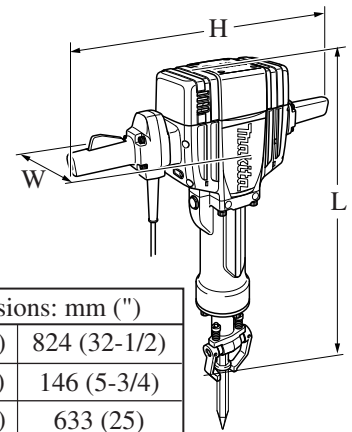
Models No. ▶ HM1810

Description ▶ Electric Breaker

## CONCEPT AND MAIN APPLICATIONS

Model HM1810 has been developed as 28.6mm hex shank electric breaker conforming to the permissible noise level limit of 2006 stage of European Noise Directive for Outdoor Equipment.

Despite such low noise level, features highest-in-class chipping efficiency. Also features unique Makita AVT (Anti-Vibration Technology), ensuring incredibly low vibration.



Dimensions: mm (")	
Length (L)	824 (32-1/2)
Width (W)	146 (5-3/4)
Height (H)	633 (25)

## ► Specification

Voltage (V)	Current (A)	Cycle (Hz)	Continuous Rating (W)		Max. Output(W)
			Input	Output	
110	16.0	50/60	1,700	950	2,300
120	15.0	AC/DC	1,700*1	950	2,300
220	9.6	50/60	2,000	1,240	2,500
230	9.2	50/60	2,000	1,240	2,500
240	8.8	50/60	2,000	1,240	2,500

\*1: Continuous Rating Input: Taiwan=1,570W, UK (low voltage)=1,700W, Saudi Arabia (low voltage)=1,650W

Specification	Model	HM1810
Blows per min.: bpm=min <sup>-1</sup>		1,100
Shank: mm (")		Hex 28.6 (1-1/8)
Impact energy: J (catalog value)		63
Anti-vibration technology	Vibration absorbing handle	No
	Counterweight mechanism	No
Noise*2: dB(A)	Permissible noise level limit*3	111
	Guaranteed noise level on the catalog for European countries	107
Vibration*4: m/s <sup>2</sup>		8
Protection from electric shock		Double insulation
Power supply cord: m (ft)		5.0 (16.4) [brazil only: 2.0m (6.6ft)]
Net weight: Kg (lbs)		32 (70.6)

\*2: Noise indicates sound power level.

\*3: This is the permissible noise level limit of 2006 stage of the "European Noise Directive for Outdoor Equipment" (2000/14/EC). And in and after 2006, it will be prohibited in Europe to sell the products with the sound power level exceeding this noise level limit.

The values of the permissible noise level limit listed above are calculated by us in accordance with the directive. (The calculation is based on the weight of product.)

\*4: Vibration level on the catalog for European countries

## ► Standard equipment

Hex wrench 5 ..... 1 pc

Note: The standard equipment for the tool shown above may differ by country.

## ► Optional accessories

Bull point                      Clay spade  
Cold chisel                      Rammer  
Scaling chisel

## ► Repair

**CAUTION: Disconnect the machine from the power source for safety before repair/maintenance!**

### [1] NECESSARY REPAIRING TOOLS

Code No.	Description	Use for
1R005	Retaining Ring R Pliers RT-2N	Removing Retaining ring R-80 from Crank box
1R023	Pipe Ring (for arbor press)	Removing Helical gear 47
1R045	Gear extractor, large	Disassembling Tool retainer section
1R346	Center Attachment for 1R045	
1R347	Jig for Tool Retainer Disassembling	
1R348	Spring Pin Extractor	Removing Spring pin 8-40 from Tool retainer shaft
1R231	1/4" Hex Shank Bit for M8	Loosening/ tightening Hex socket head bolt M8x75
1R263	Bearing Extractor	Removing Ball bearings
1R269	Bearing Extractor	
1R291	Retaining Ring S and R Pliers	Removing Retaining ring S-20 from Crank shaft
784408-3	Socket Bit 13-55	Loosening/ tightening Hex nut M8 that secures Fan 100

### [2] ADHESIVE APPLICATION AND LUBRICATION

#### [2] -1. Adhesive Application

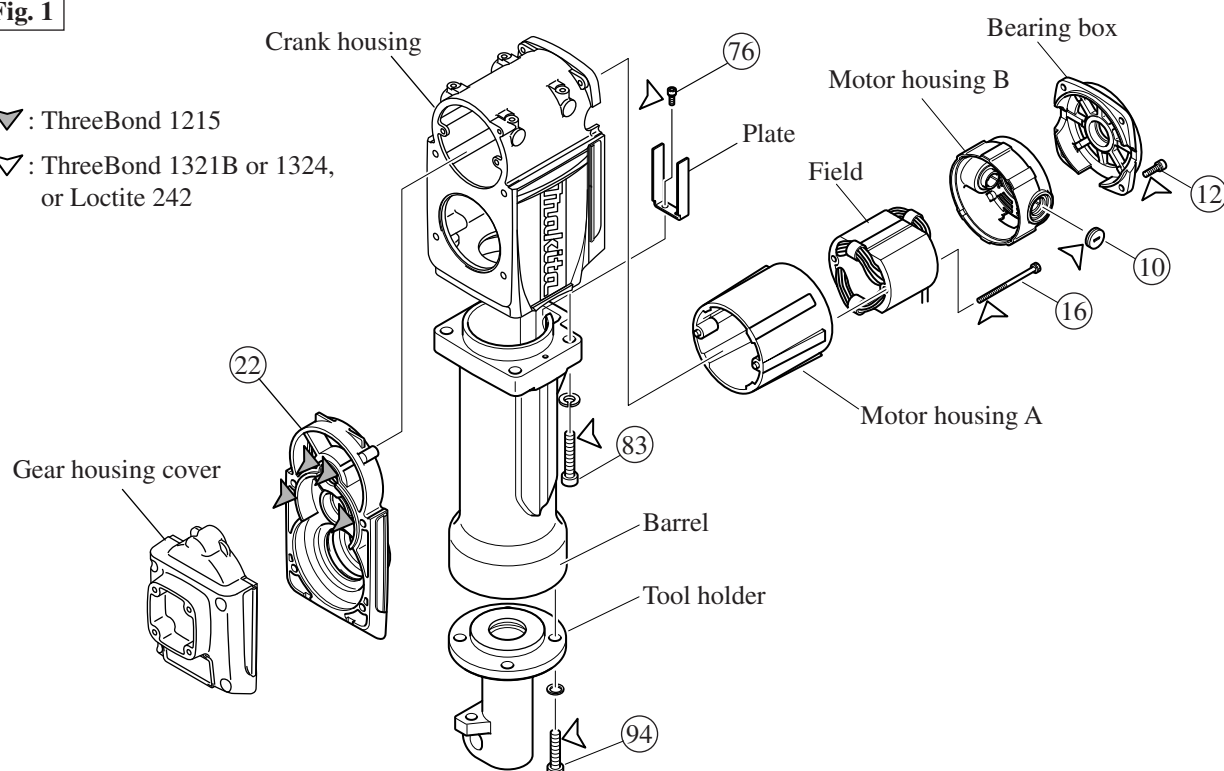
Apply an appropriate amount of adhesive to the following parts in order to lock them against vibration loosening or leakage. Be sure to wipe off grease or oil from the parts before adhesive application.

Item No.	Description	Portion to apply adhesive
10	Brush holder cap (2pcs)	Threaded portion
12	Hex socket head bolt M6x22 (4pcs)	Threaded portion
16	Hex bolt M5x85 (2pcs)	Threaded portion
22	Gear housing complete	Figure 8 inlaid portion that contacts Gear housing cover
76	Hex socket head bolt M5x16 (2pcs)	Threaded portion
83	Hex socket head bolt M12x55 (4pcs)	Threaded portion
94	Hex socket head bolt M12x45 (4pcs)	Threaded portion

**Fig. 1**

▼ : ThreeBond 1215

▼ : ThreeBond 1321B or 1324,  
or Loctite 242



## ► Repair

### [2] LUBRICATION

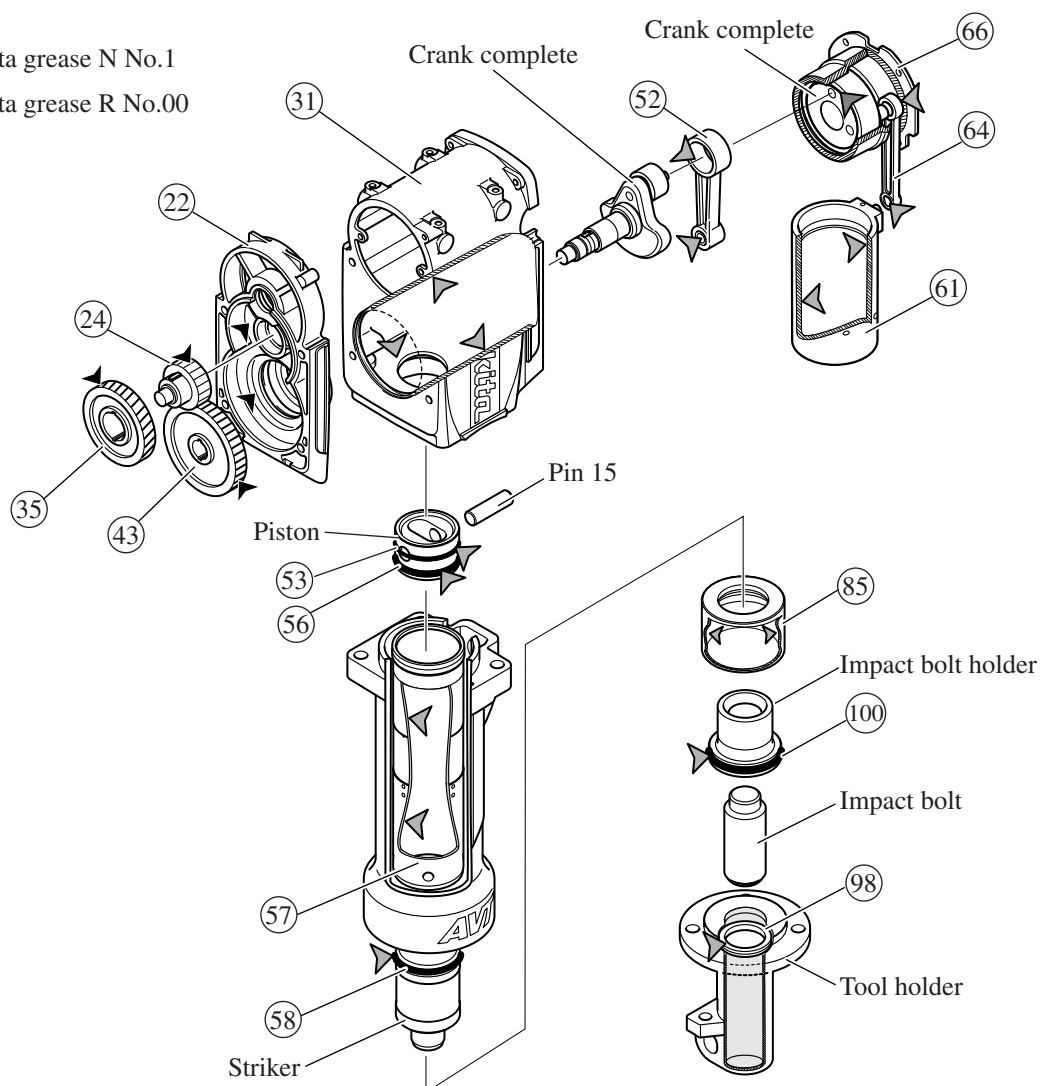
Apply Makita grease to the following portions designated with the black triangle and gray triangle to protect parts and product from unusual abrasion.

Item No.	Description	Portion to lubricate
22	Gear housing complete	approx. 80g of Makita grease N No.1 in the gear chambers
24	Spur gear 22	appropriate amount of Makita grease N No.1 to the teeth portion
31	Crank housing	approx. 110g of Makita grease R No.00 in the crank room
35	Helical gear 50	appropriate amount of Makita grease N No.1 to the teeth portion
43	Spur gear 47	appropriate amount of Makita grease N No.1 to the teeth portion
52	Connecting rod	appropriate amount of Makita grease R No.00 to the inside surface of the two holes
53	O ring 55	appropriate amount of Makita grease R No.00 to the whole portion
56, 58	O ring 52	appropriate amount of Makita grease R No.00 to the whole portion
57	Cylinder liner 62	approx. 10g of Makita grease R No.00 to the inside
61	Balancer complete	appropriate amount of Makita grease R No.00 to the inside surface
64	Connecting rod	appropriate amount of Makita grease R No.00 to the inside surface of the two holes
66	Crank box	approx. 20g of Makita grease R No.00 to the rollers of Needle bearing
85	Cylinder B	appropriate amount of Makita grease R No.00 to the inside surface
98	X ring 40	appropriate amount of Makita grease R No.00 to the whole portion
100	O ring 60	appropriate amount of Makita grease R No.00 to the whole portion

**Fig. 2**

▼ : Makita grease N No.1

▽ : Makita grease R No.00



## ► Repair

### [3] DISASSEMBLY/ASSEMBLY

#### [3] -1. Disassembling/Assembling Motor Section

##### REMOVING FIELD

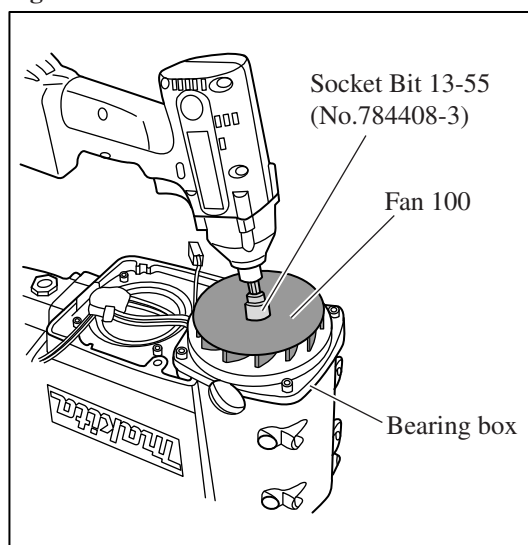
- 1) Remove Motor housing cover set. Fan 100 secured with Hex nut M8 will be now visible.
- 2) Remove the assembly of Rear cover and Handle (switch side), then Brush holder caps and Carbon brushes.

##### Important:

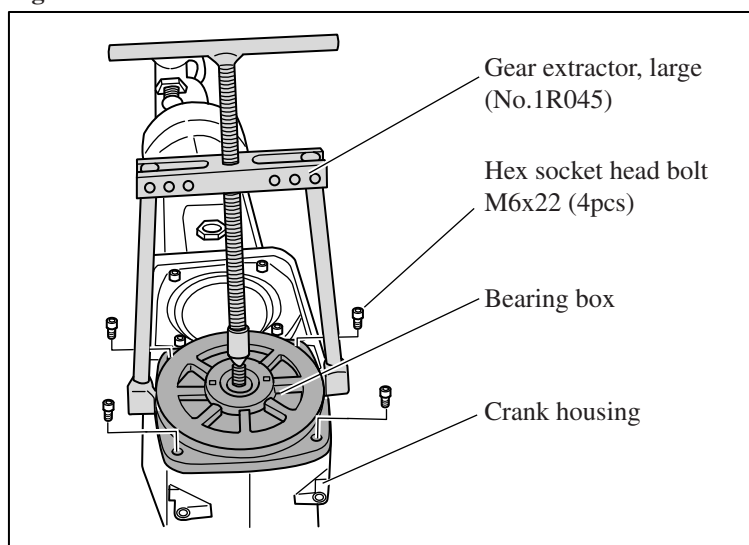
When unscrewing Brush holder caps, be careful not to break the screwdriver insertion slot because the adhesive-applied Brush holder caps are secured tight.

- 3) Remove hex nut M8 by turning counterclockwise with Socket bit 13-55 (No.784408-3) and Impact driver. Now Fan 100 can be separated from Armature shaft. (**Fig. 3**)
- 4) After unscrewing four M6x22 Hex socket had bolts, remove Bearing box from Crank housing using Gear extractor, large (No.1R045). (**Fig. 4**)

**Fig. 3**

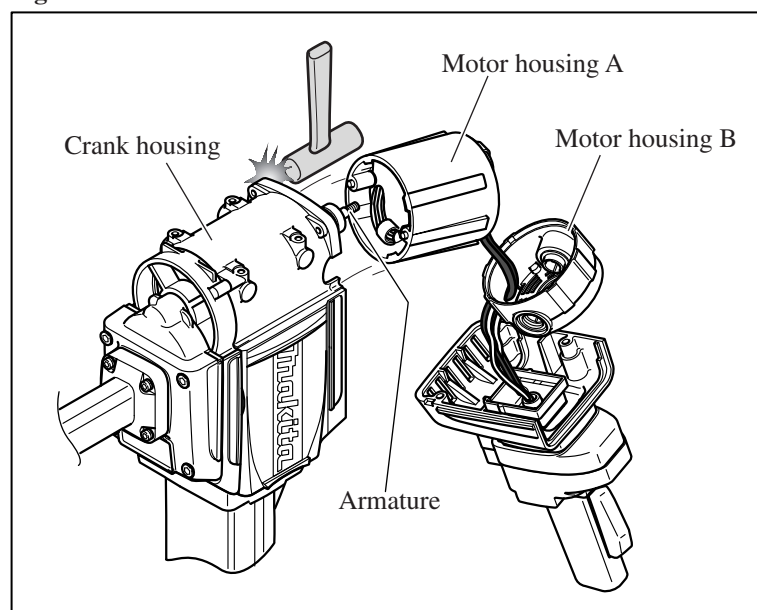


**Fig. 4**

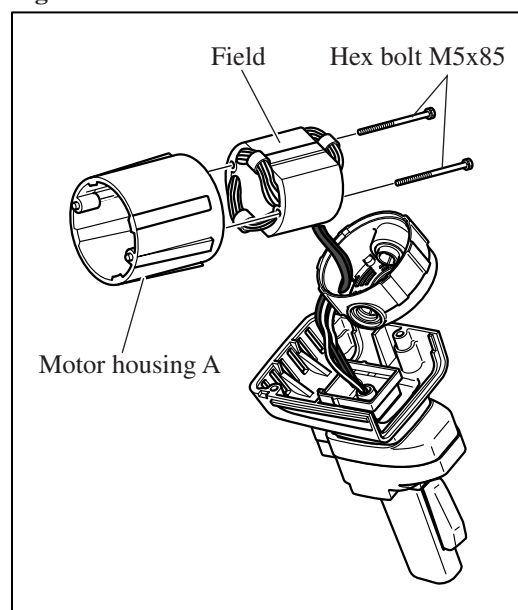


- 5) Pull off Motor housing B from Crank housing. Then remove Motor housing A from Crank housing by tapping the edge of Crank housing with plastic hammer. (**Fig. 5**) Sometimes, when tapping Crank housing, Armature may be removed from Crank housing before Motor housing A.
- 6) After unscrewing two M5x85 Hex bolts, remove Field by tapping the edge of Motor housing A with plastic hammer. (**Fig. 6**)

**Fig. 5**



**Fig. 6**



► **Repair**

**[3] DISASSEMBLY/ASSEMBLY**

**[3] -1. Disassembling/Assembling Motor Section (cont.)**

**INSTALLING FIELD**

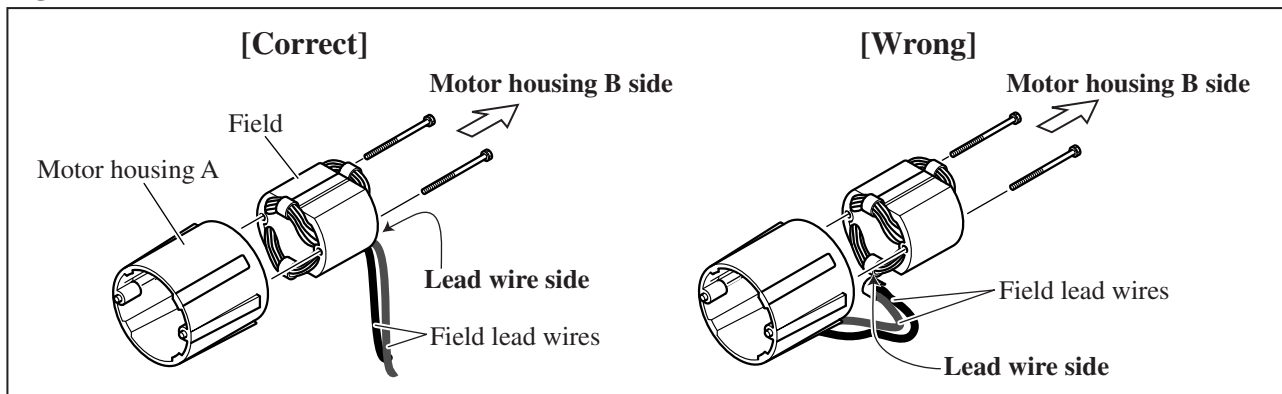
Do the reverse of the disassembling steps.

**Important:**

Field is not reversible when assembled into Motor housing A. Be sure to assemble so that the Lead wire side of the Field is placed on the Motor housing B side as illustrated to **left** in Fig. 7.

It will be impossible to route the lead wires to Motor housing B if assembled as illustrated to **right** in Fig. 7.

**Fig. 7**



**REMOVING ARMATURE**

If Armature is not removed in removal of Field as described in 5) of "Removing Field", remove by following the steps described below:

- 1) Remove the parts of Fan 100 side (Fan 100, Bearing box and Motor housing B). (See Figs. 3, 4, 5)

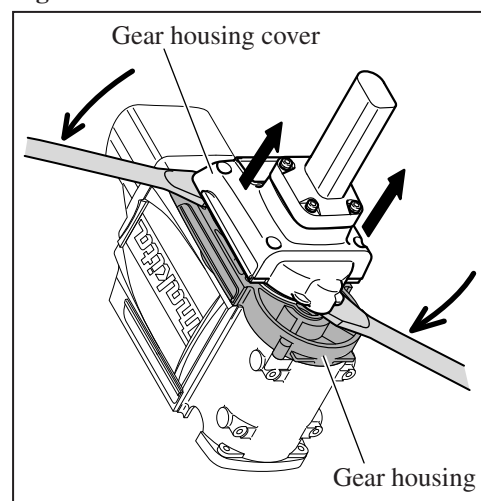
**Note:** It is not necessary to remove Motor housing A and Field. Remove four M8x75 Hex socket head bolts with 1R231.

- 2) Remove Gear housing cover by raising with Slotted screwdriver and Bearing extractor (No.1R263) as in Fig. 8.

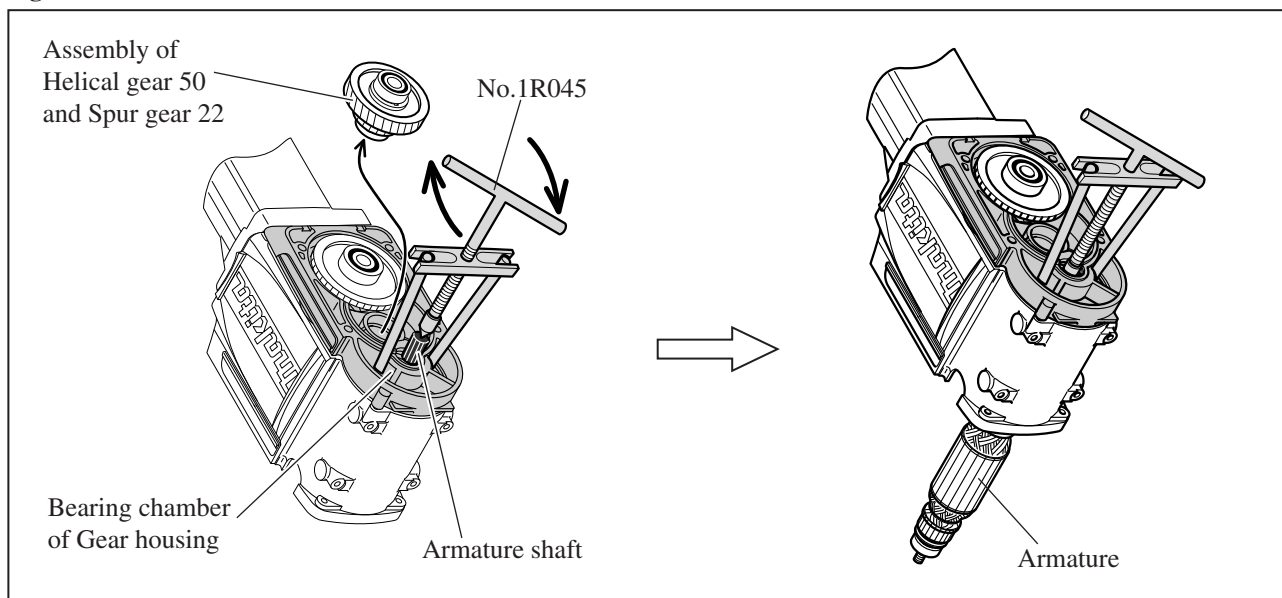
**Note:** The two tools are necessary because Gear housing cover is securely fastened to Gear housing using adhesive.

- 3) After removing the assembly of Helical gear 50 and Spur gear 22, insert the arms of 1R045 through the opening of Gear housing. Then grip the bearing chamber of Gear housing with the jaws of 1R045. Now, by turning the handle of 1R045 clockwise, Armature can be removed from Gear housing. (Fig. 9)

**Fig. 8**



**Fig. 9**



► **Repair**

**[3] DISASSEMBLY/ASSEMBLY**

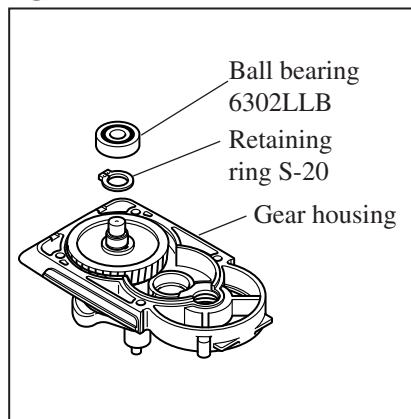
**[3] -2. Disassembling/Assembling Gear Section**

**DISASSEMBLING**

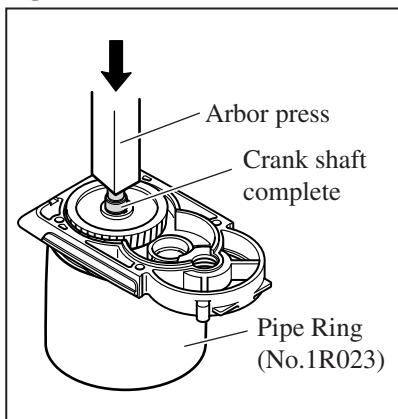
- 1) After separating Gear housing from Crank housing, remove Ball bearing 6302LLB with Gear extractor, large (No.1R045). At this time, be careful not to lose Pin 5. Then using Retaining ring S and R pliers (No.1R291) remove Retaining ring S-20. **(Fig. 10)**
- 2) Put Gear housing on Pipe Ring (No.1R023), and press down Crank shaft using arbor press. **(Fig. 11)**
- 3) Now Crank shaft complete, Spur gear 47 and Sleeve 25 can be removed from Gear housing. **(Fig. 12)**

**Note:** Be careful not to lose two woodruff keys.

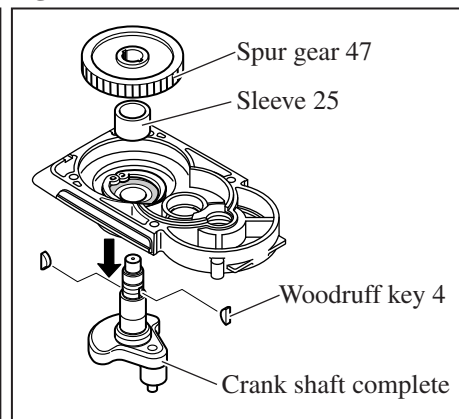
**Fig. 10**



**Fig. 11**



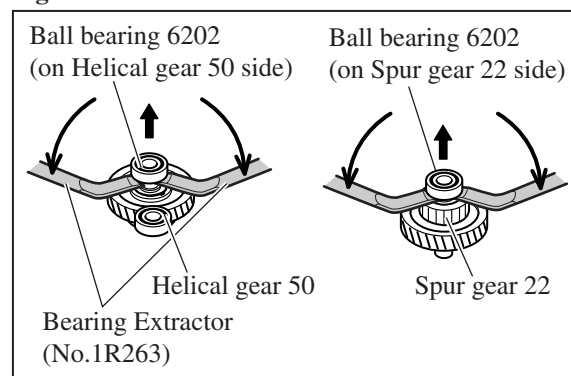
**Fig. 12**



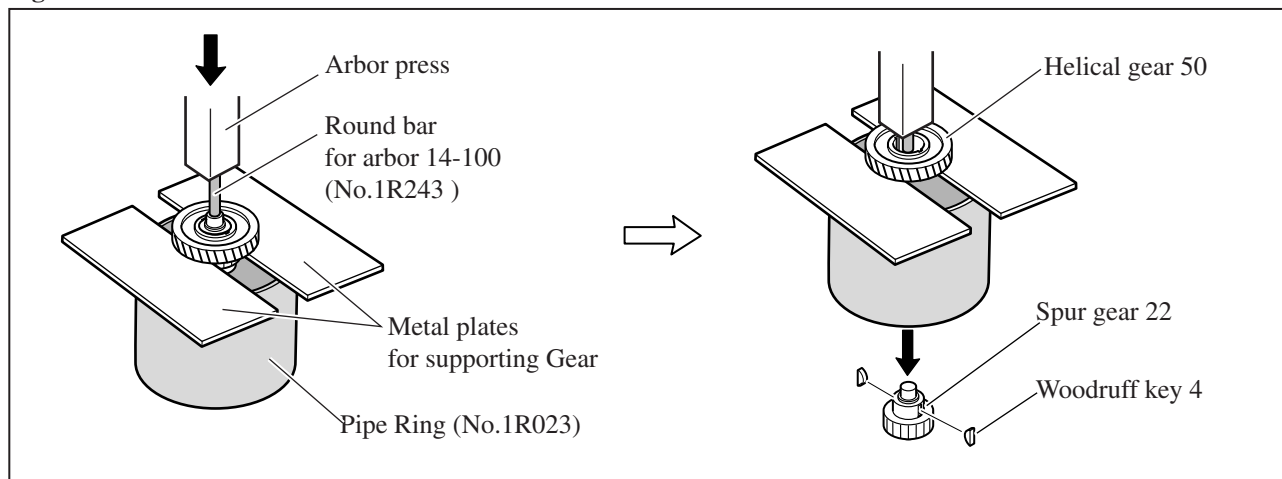
- 4) Two 6202 Ball bearings can be removed from the assembly of Helical gear 50 and Spur gear 22 using Bearing extractors (No.1R263) as illustrated in **Fig. 13**.
- 5) As illustrated in **Fig. 15**, the assembly of Helical gear 50 and Spur gear 22 can be disassembled using Pipe ring (No.1R023), Round Bar for Arbor 14-100 (No.1R243), arbor press and two appropriate steel plates.

**Note:** Be careful not to lose two Woodruff keys.

**Fig. 13**



**Fig. 14**





## ► Repair

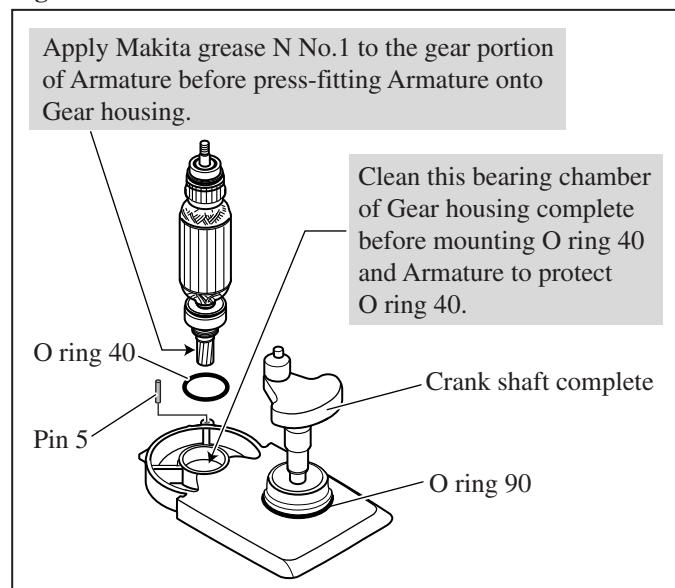
### [3] DISASSEMBLY/ASSEMBLY

#### [3] -2. Disassembling/Assembling Gear Section (cont.)

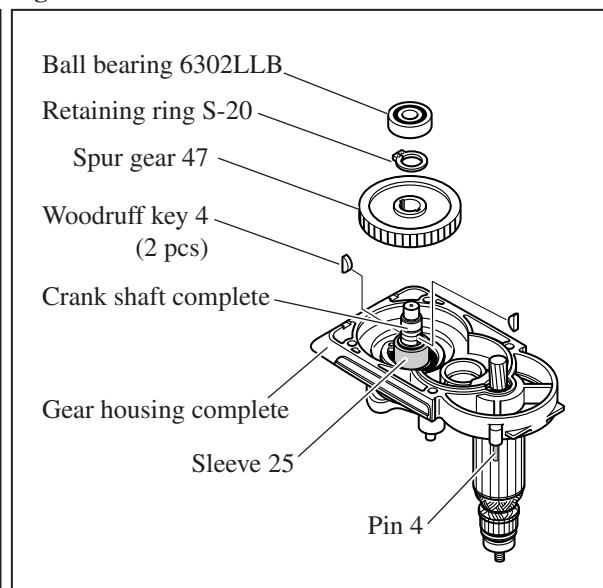
##### ASSEMBLING

- 1) After setting O ring 40, O ring 90 and Pin 4 in place on Gear housing complete, press-fit Crank shaft complete and Armature onto Gear housing using arbor press as illustrated in **Fig. 15**.
- 2) Put Sleeve 25 through Crank shaft complete. Set woodruff keys onto the concaves of Crank shaft complete. Mount Spur gear 47 to Crank shaft complete. After fixing Spur gear 47 with Retaining ring S-20, assemble Ball bearing 6302LLB to Crank shaft complete. (**Fig. 16**)

**Fig. 15**

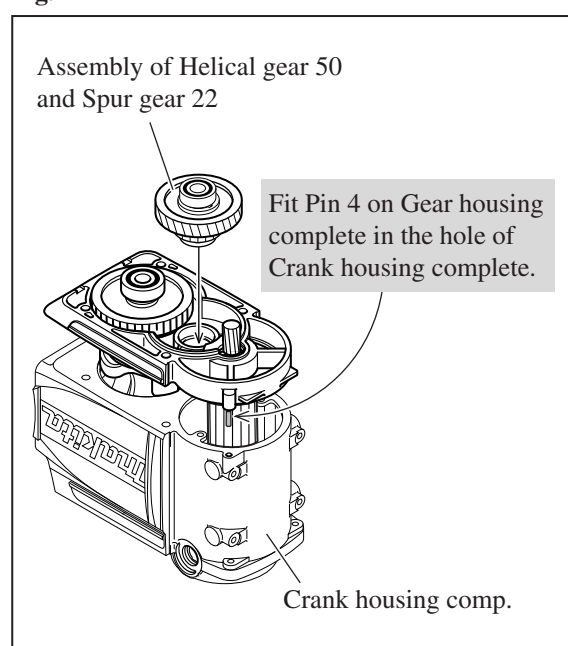


**Fig. 16**

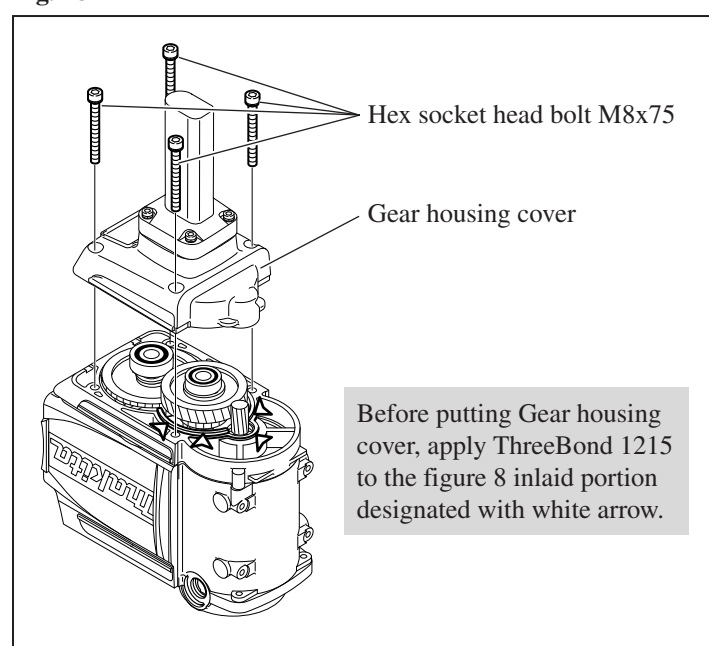


- 3) Assemble Helical gear 50 to Spur gear 22. Mount the assembly to Gear housing complete.
- 4) Put Gear housing complete onto Crank housing complete as illustrated in **Fig. 18**.
- 5) Apply an appropriate amount of ThreeBond 1215 to the figure 8 inlaid portion that contacts Gear housing cover. Then secure Gear housing cover to Gear housing complete with four M8x75 Hex socket head bolts. (**Fig. 19**)

**Fig. 17**



**Fig. 18**



► **Repair**

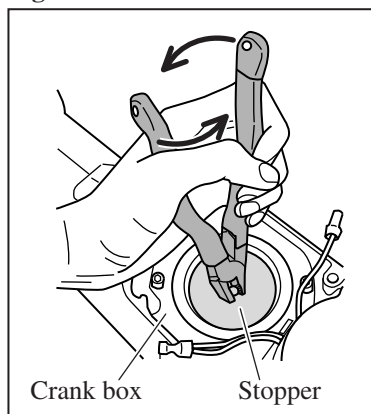
**[3] DISASSEMBLY/ASSEMBLY**

**[3] -3. Disassembling/Assembling Crank Section of AVT**

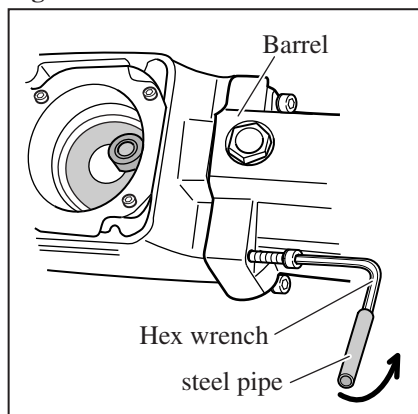
**DISASSEMBLING**

- 1) Stopper and Crank box will be visible by removing Motor housing cover set and the assembly of Rear cover and Handle (switch side).
- 2) Grasp the projection of Stopper with pliers. While turning Stopper, pull off from Crank box. (**Fig. 19**)
- 3) Unscrew four M12x55 hex socket head bolts with hex wrench. (**Fig. 20**)  
**Note:** Use an appropriate steel pipe to extend the grip of hex wrench for easy removal of the bolts securely fastened with adhesive.
- 4) Move Barrel till the connection portion of Balancer comp. and Connecting rod (for balancer reciprocating) is visible. Now Connecting rod can be removed from Balancer complete and Crank complete as illustrated in **Fig. 21**.

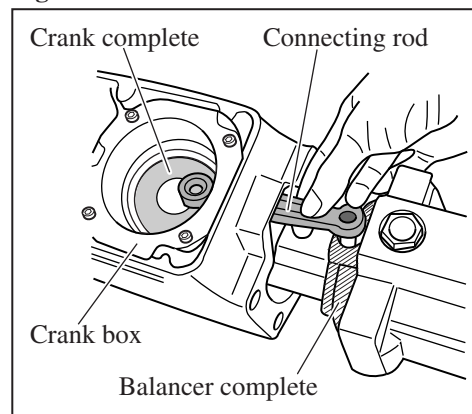
**Fig. 19**



**Fig. 20**

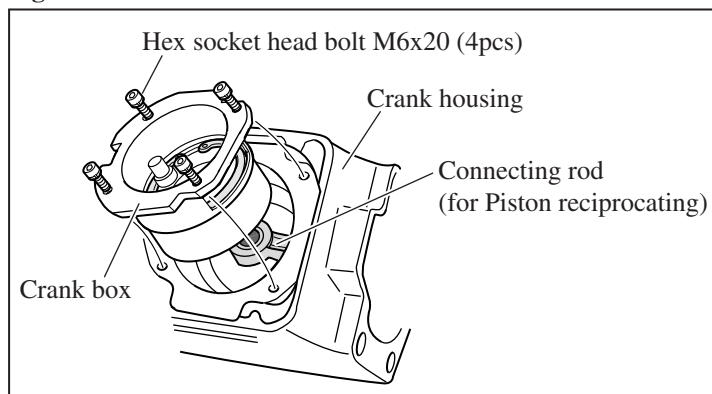


**Fig. 21**

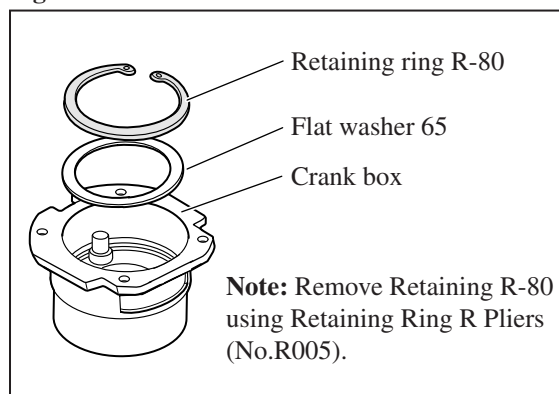


- 5) Remove Crank box from Crank housing by unscrewing four M6x20 Hex socket head bolts. (**Fig. 22**)
6. Remove Retaining ring R-80 and Flat washer 65 from Crank box. (**Fig. 23**)

**Fig. 22**

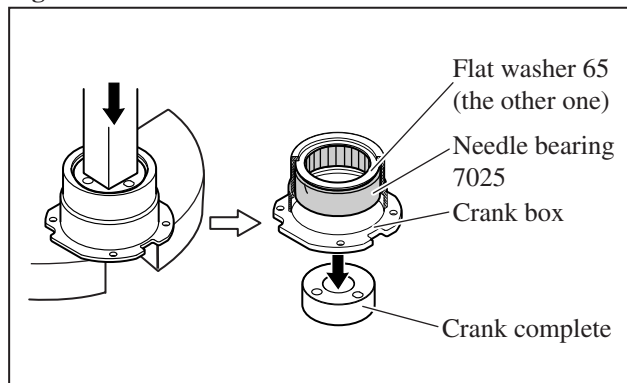


**Fig. 23**

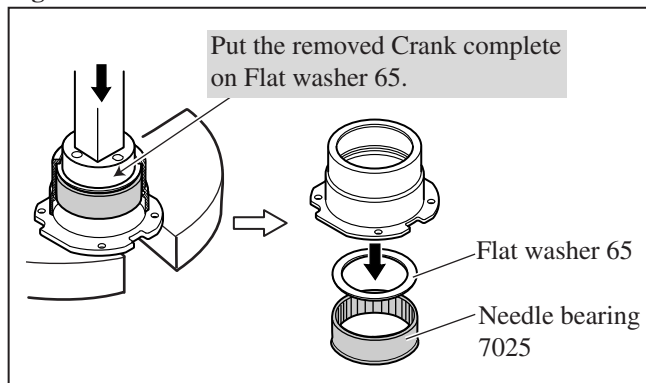


- 7) Remove Crank by pressing with arbor press. (**Fig. 24**)  
 The other Flat washer 65 and Needle bearing 7025 still remain in Crank box in this step.
- 8) Needle bearing 7025 and the other Flat washer 65 can be removed from Crank box by putting the Crank complete removed in the previous step on Flat washer 65, then pressing it with arbor press. (**Fig. 25**)

**Fig. 24**



**Fig. 25**





## ► Repair

### [3] DISASSEMBLY/ASSEMBLY

#### [3] -3. Disassembling/Assembling Crank Section of AVT (cont.)

##### ASSEMBLING

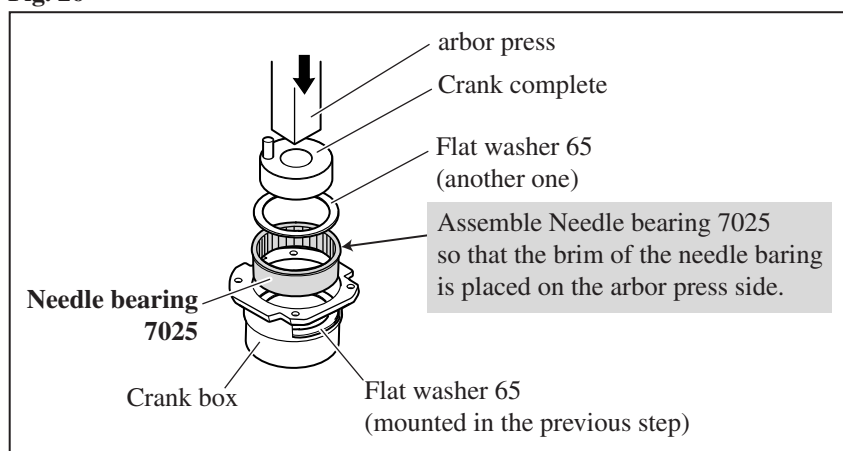
- 1) Put Flat washer 65 into Crank box.
- 2) Then, as illustrated in **Fig. 26**, press-fit Needle bearing 7025 into Crank box using Crank complete and the other Flat washer 65 as jigs,

##### Important:

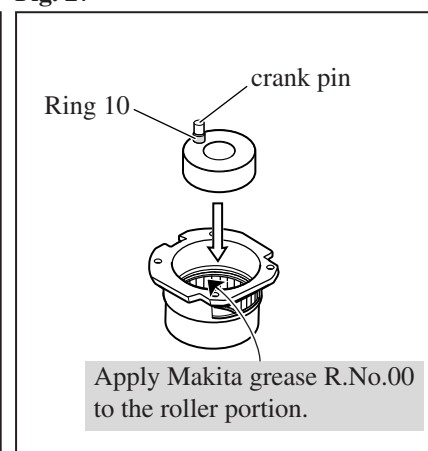
Needle bearing 7025 is not reversible when assembled into Crank box. Be sure to assemble as illustrated in **Fig. 26**.

- 3) Put Ring 10 through the crank pin on Crank complete. Then apply Makita grease R.No.00 to the roller portion of Needle bearing 7025, then assemble Crank complete into the Needle bearing. (**Fig. 27**)
- 4) Put the other Flat washer 65 into Crank box. With retaining ring R-80, fix the parts assembled into Crank box. Then make sure that Crank complete rotates easily by finger.

**Fig. 26**



**Fig. 27**

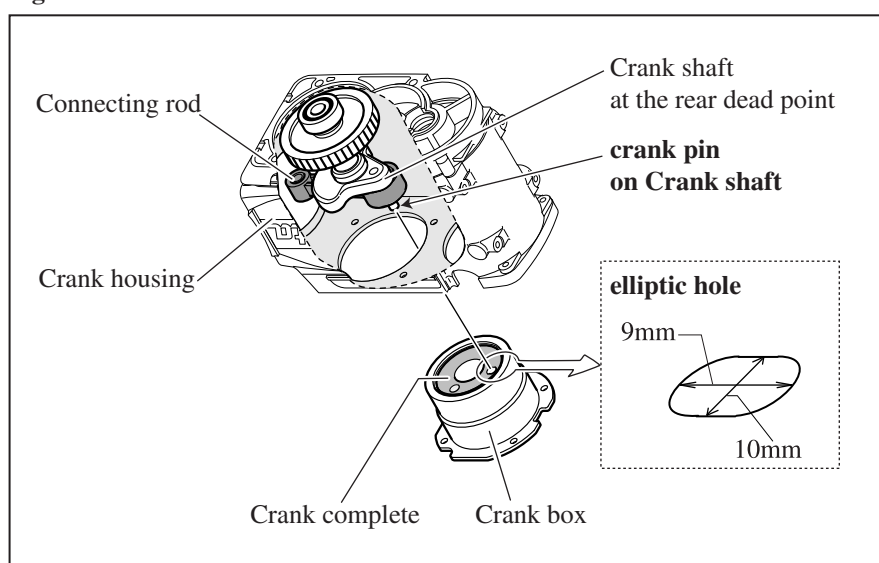


- 5) Move Crank shaft to the rear dead point (or to the front dead point). Then, aligning the elliptic hole of Crank complete with the crank pin on Crank shaft, fit Crank box to Crank housing. (**Fig. 28**)

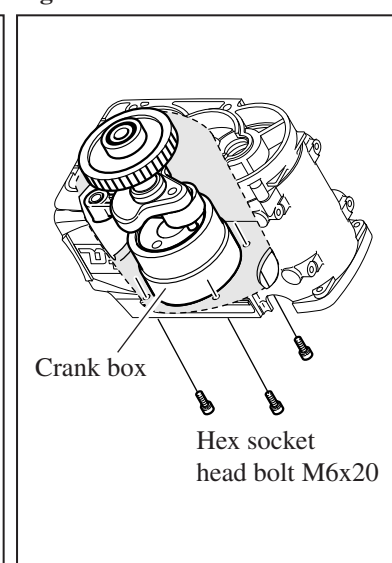
If the crank pin is not completely inserted into the elliptic hole or positioned on the wrong hole, a gap of approx. 5mm will occur between the brim of Crank box and Crank housing. In this case, turn Crank shaft slowly until the crank pin is completely inserted in the elliptic hole to eliminate the gap.

- 6) Secure Crank box to Crank housing with four M6x20 hex socket head bolts. (**Fig. 29**)
- 7) Do the reverse of the disassembling steps from 1) to 4).

**Fig. 28**



**Fig. 29**



## ► Repair

### [3] DISASSEMBLY/ASSEMBLY

#### [3] -4. Disassembling/Assembling Barrel Section

##### DISASSEMBLING

- 1) Remove Stopper, Connecting rod (for balancer reciprocating) and Crank box. (See 1) to 5) of [3] -3.)
- 2) From Crank housing, separate Barrel then the assembly of Cylinder liner 62 and Balancer complete. (Fig. 30A)  
**Note:** When replacing Barrel with new one, replace Plate (the guide for Balancer complete) at the same time.  
 When reusing two M5x16 Hex socket bolts, apply appropriate amount of adhesive to them. (Fig. 30B)
- 3) Take out Striker from Cylinder liner 62, then remove O ring 52 from Striker. (Fig. 30C)
- 4) Take out Piston and Connecting rod (for Piston reciprocating) from Crank housing complete, and remove O ring 52 and O ring 55 from the removed Piston. (Fig. 30D)

Fig. 30A

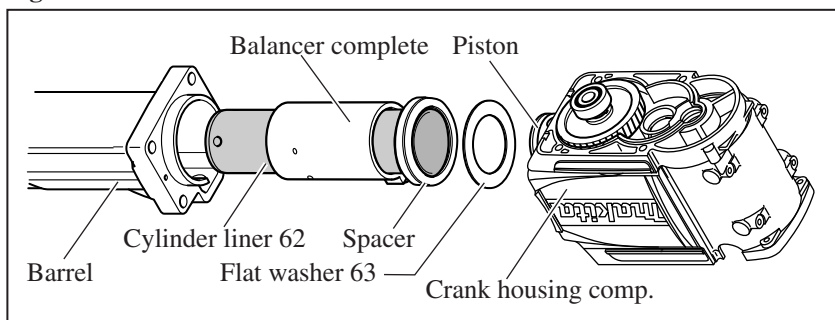


Fig. 30B

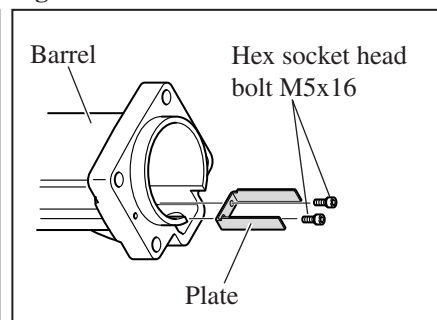


Fig. 30C

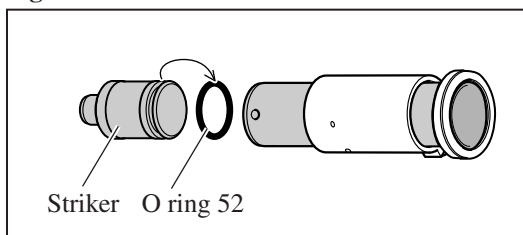
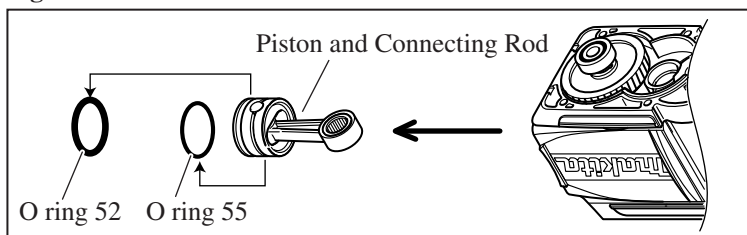


Fig. 30D



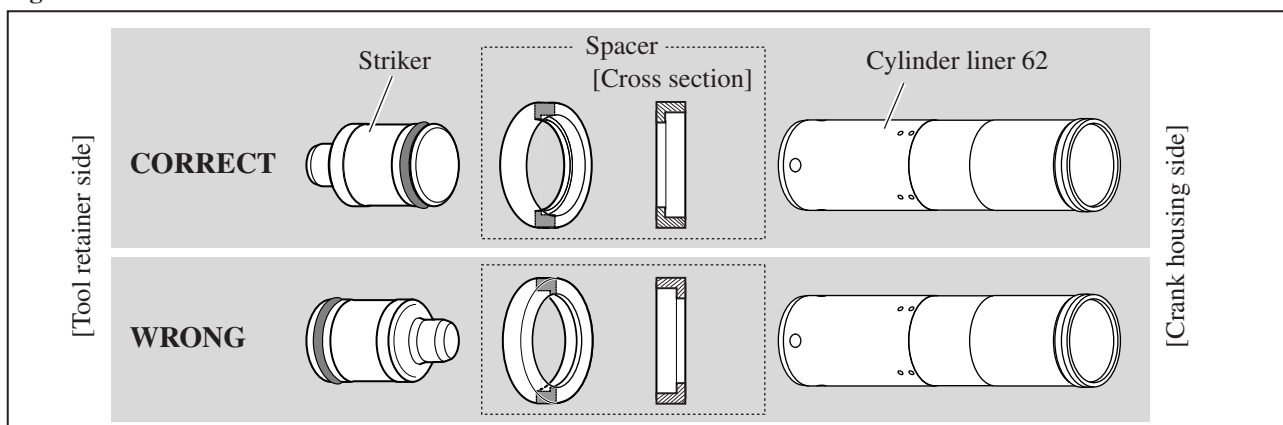
##### ASSEMBLING

Do the reverse of the disassembling steps.

##### Note:

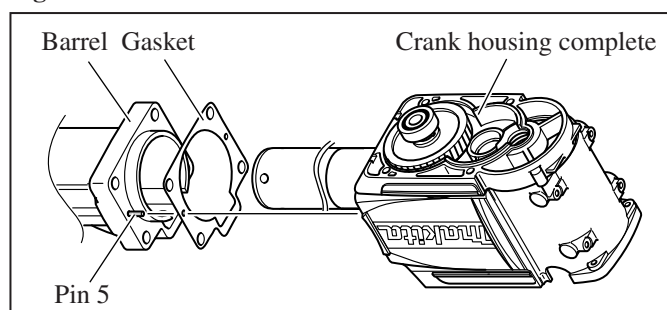
- Striker and Spacer are not reversible when assembled to Cylinder liner 62. Be sure to install as illustrated in Fig. 31.

Fig. 31



- Do not forget to put Flat washer 63 between Cylinder liner 62 and Crank housing complete.
- When assembling Barrel to Crank housing complete, first fit Pin 5 in the hole on Barrel, and put the pin through the hole of Gasket. Then fit Barrel to Crank housing complete so that Pin 5 is inserted into the hole on Crank housing complete. (Fig. 32)

Fig. 32



► **Repair**

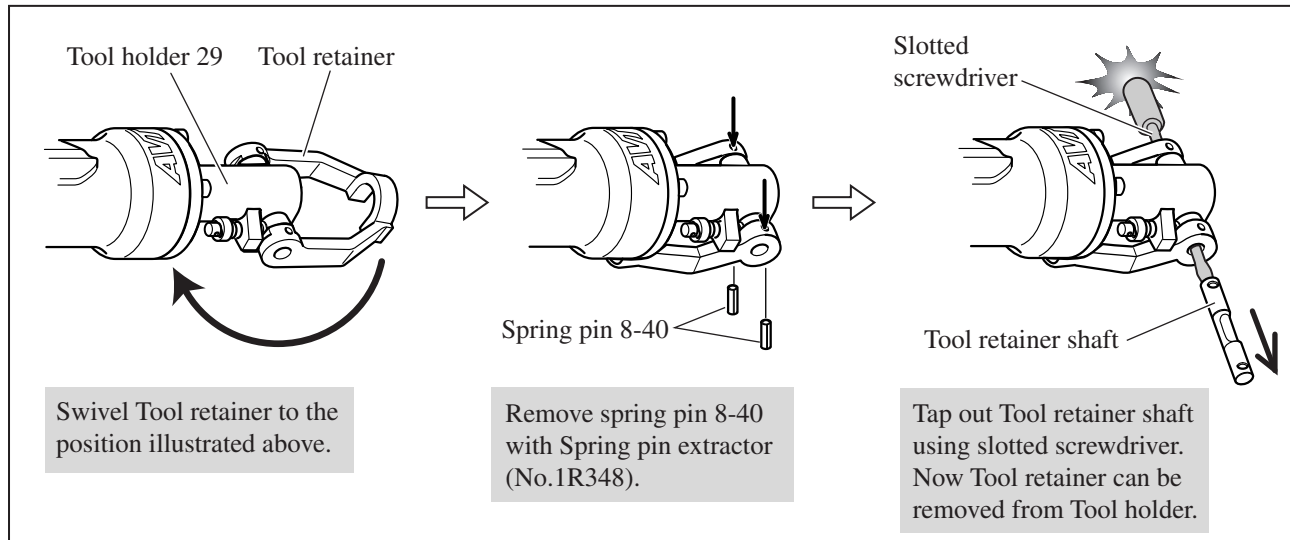
**[3] DISASSEMBLY/ASSEMBLY**

**[3] -5. Disassembling/Assembling Tool Retainer Section**

**DISASSEMBLING**

1) Tool retainer can be removed as illustrated in **Fig. 33**.

**Fig. 33**



2) For removing Tool retainer poles, first set Gear extractor, large (No.1R045) as illustrated in **Fig. 34**.

\*Attach Center attachment (No.1R346) to No.1R045.

\*Adjust the pitch of the arms of No.1R045 to minimum for securely holding Retainer ring.

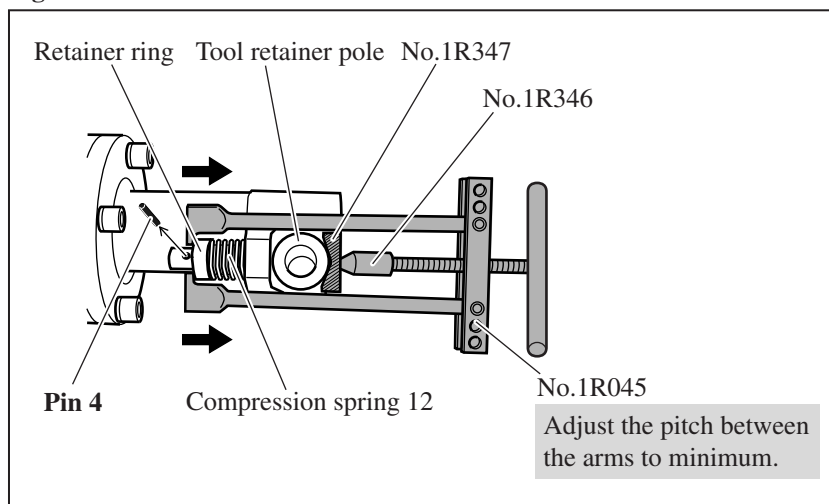
\*Set Tool retainer pole removing tool (No.1R347) between No.1R346 and Tool retainer pole.

3) Then pull Retainer ring in the direction of Tool retainer pole by turning the handle of 1R045 clockwise, and remove Pin 4 from the rod hole of Tool retainer pole by hand. (**Fig. 34**)

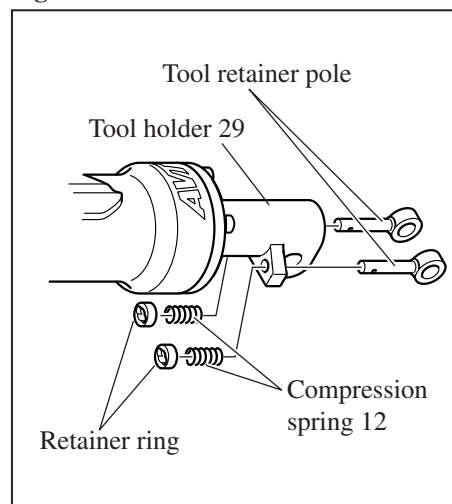
Be sure to securely hold the arms of No.1R045 not to spread out, or the arms will fall off from retainer ring and Compression spring and Retainer ring will fly away.

4) Slowly loosen the handle of No.1R045 by turning counterclockwise until Retainer ring is released from Compression spring 12. Now Tool retainer pole can be removed from Tool holder 29. (**Fig. 35**)

**Fig. 34**



**Fig. 35**



► **Repair**

**[3] DISASSEMBLY/ASSEMBLY**

**[3] -5. Disassembling/Assembling Tool Retainer Section (cont.)**

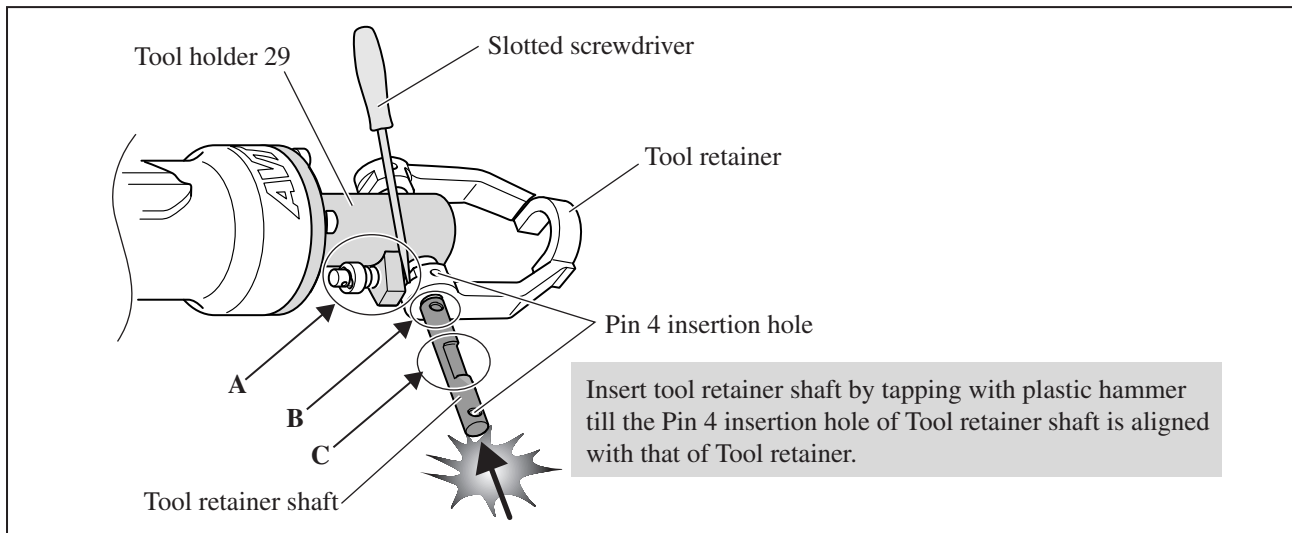
**ASSEMBLING**

Do the reverse of the disassembling steps.

**Note:**

When assembling Tool retainer to Tool holder 29, follow the instructions described below. (Fig. 36 - 39)

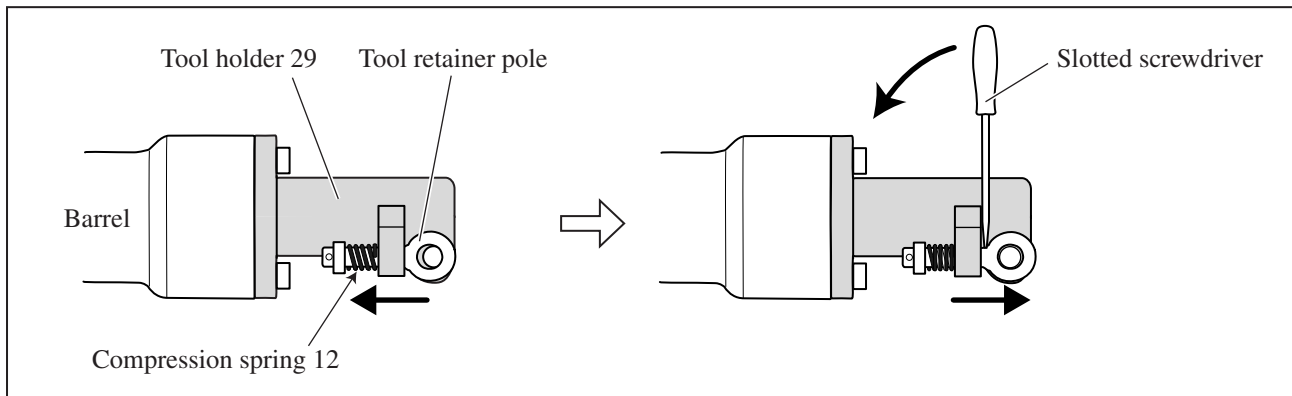
**Fig. 36**



A) See Fig. 37. As illustrated to **left**, when assembled to Tool holder 29, Tool retainer pole is pulled in the direction of Barrel by the force of Compression spring 12, and the hole of Tool retainer pole is not aligned with the hole of Tool holder 29.

Therefore, as illustrated to **right**, while aligning the two holes by sliding Tool retainer pole with slotted screwdriver, assemble Tool retainer and Tool retainer shaft to Tool holder 29.

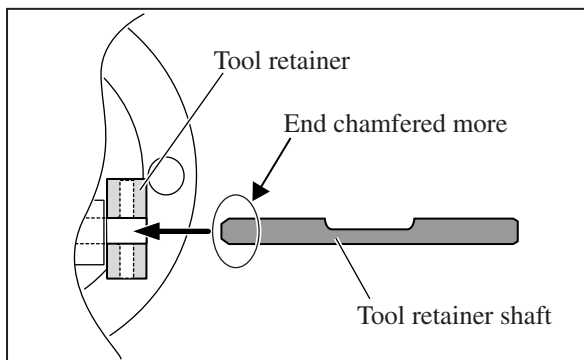
**Fig. 37**



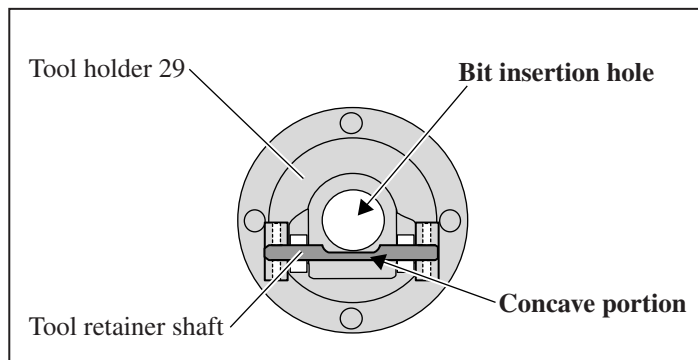
B) Insert Tool retainer shaft from the end chamfered more than the other. (Fig. 38)

C) Tool retainer shaft is not reversible when inserted into Tool retainer. As illustrated in Fig. 39, be sure to insert so that the concave portion on Tool retainer shaft is positioned on the bit insertion hole of Tool holder 29.

**Fig. 38**



**Fig. 39**



## ► Repair

### [3] DISASSEMBLY/ASSEMBLY

#### [3] -6. Disassembling/Assembling Tool Holder Section

##### DISASSEMBLING

- 1) Remove Tool retainer section from Tool holder 29. (Figs. 33, 34, 35)
- 2) Separate Tool holder 29 from Barrel by unscrewing four M12x45 Hex socket head bolts as illustrated in Fig. 40.  
**Note:** Use an appropriate steel pipe to extend the grip of hex wrench for easy removal of the bolts securely fastened with adhesive.
- 3) Remove Impact bolt by tapping the edge of Tool holder 29. (Fig. 41)
- 4) Take out X ring 40 from Tool holder 29 using small screwdriver or the like. (Fig. 42)  
 Now Tool holder 29 can be replaced. If Cylinder B is contaminated with dust, X ring 40 can be damaged. In this case, also replace X ring 40, and clean up the inside of Barrel section.
- 5) Take out Cylinder B from Barrel by tapping its edge with plastic hammer. (Fig. 43)
- 6) Take out Impact bolt holder from Cylinder B by tapping its edge with plastic hammer. Then remove O ring 53 from Cylinder B. (Fig. 44)
- 7) Remove O ring 60 and Rubber ring 54 from Impact bolt holder. (Fig. 45)

Fig. 40

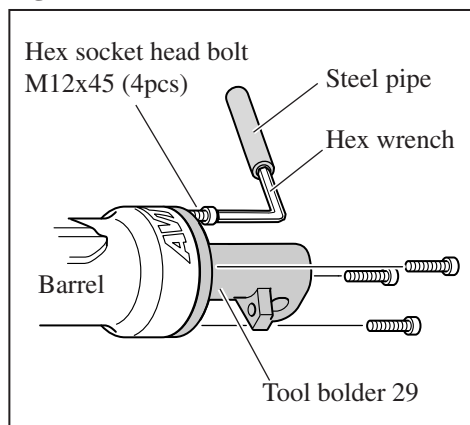


Fig. 41

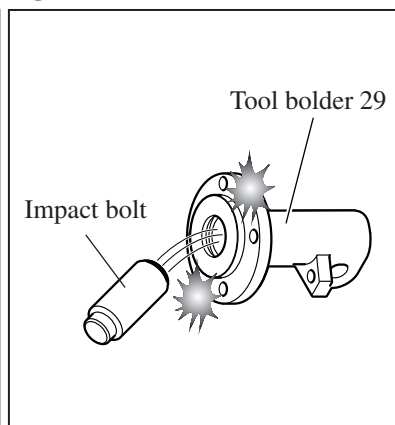


Fig. 42

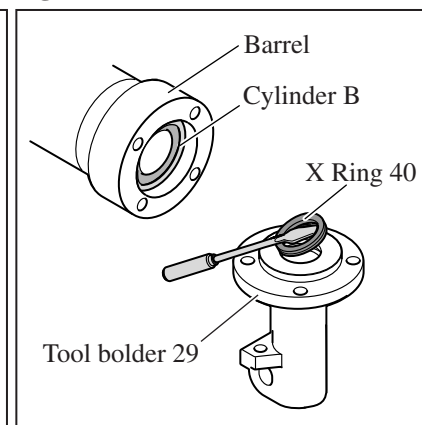


Fig. 43

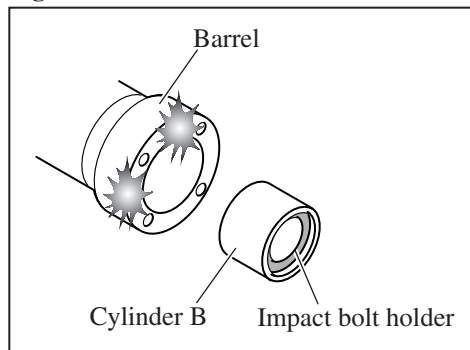


Fig. 44

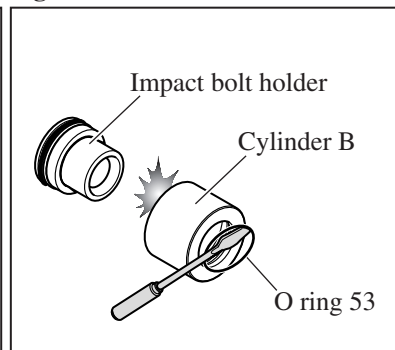
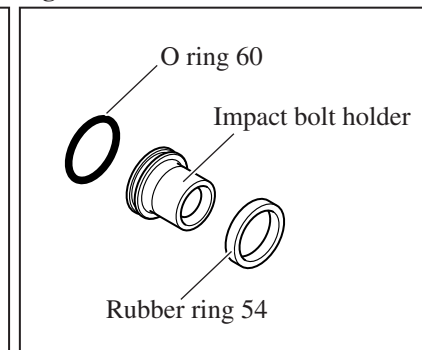


Fig. 45



##### ASSEMBLING

Do the reverse of the disassembling steps.

**Note:** Do not forget to apply adhesive to M12x45 Hex socket head bolts.



## ► Repair

### [3] DISASSEMBLY/ASSEMBLY

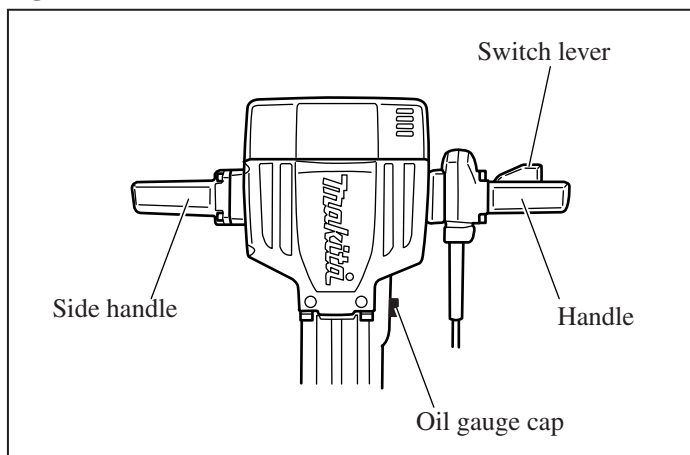
#### [3] -7. Assembling Handle

See **Fig. 46**.

When mounting Handle and Side handle, be sure to:

- a) Place Handle (on which Switch and Switch lever are installed) on the side where oil gauge cap is installed.
- b) Place Side handle on the opposite side.

**Fig. 46**

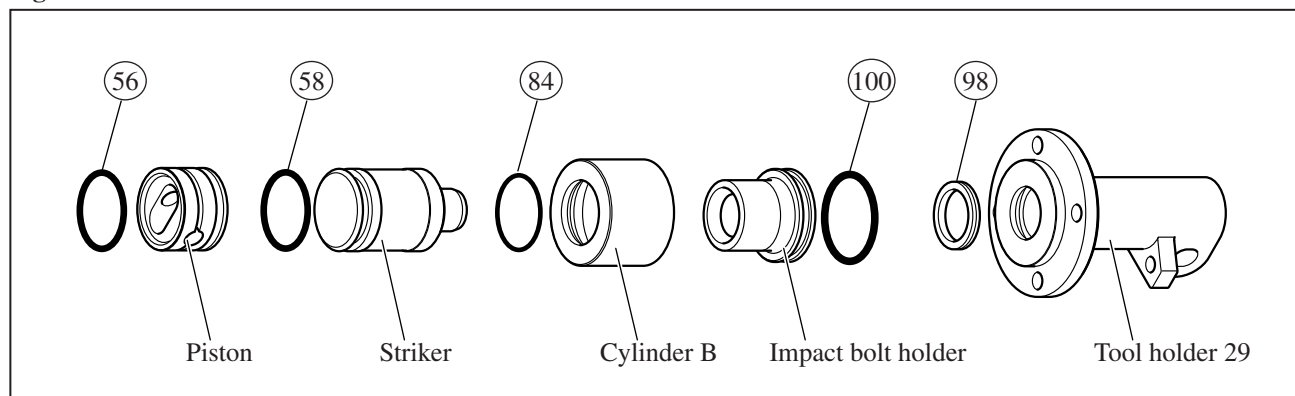


### [4] Maintenance

When replacing carbon brush, it is recommended to do the following maintenance at the same time for longer service life of the machine:






- 1) Replace the following parts (**Fig. 47**);
  56. O ring 52 mounted to Piston
  58. O ring 52 mounted to Striker
  84. O ring 53 mounted to Cylinder B
  98. X ring 40 mounted to Tool holder 29
  100. O ring 60 mounted to Impact bolt holder

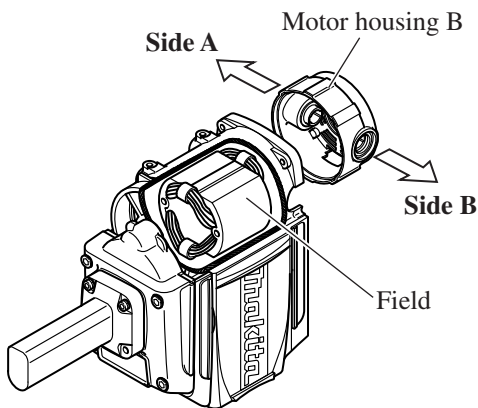
**Fig. 47**



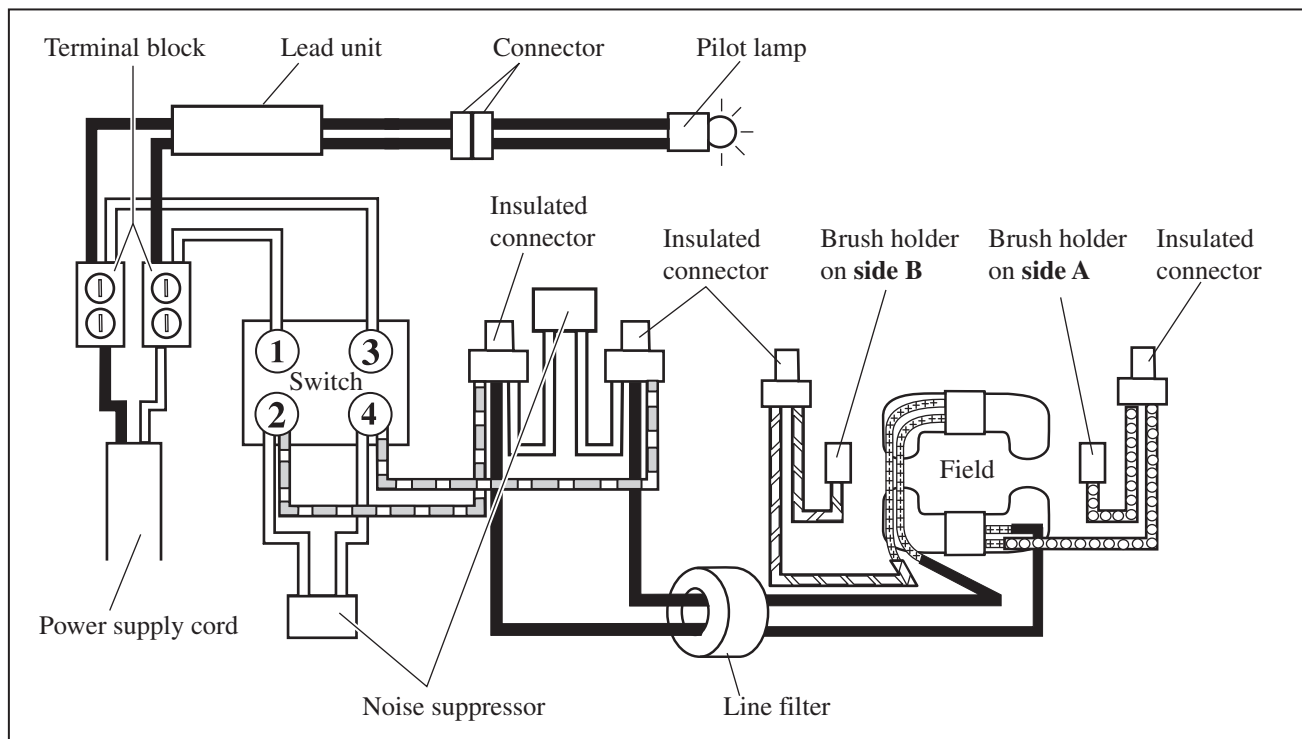
- 2) Additionally apply approx. 60g of Makita grease R No.00 to the inside of Crank housing complete.

► **Circuit diagram**

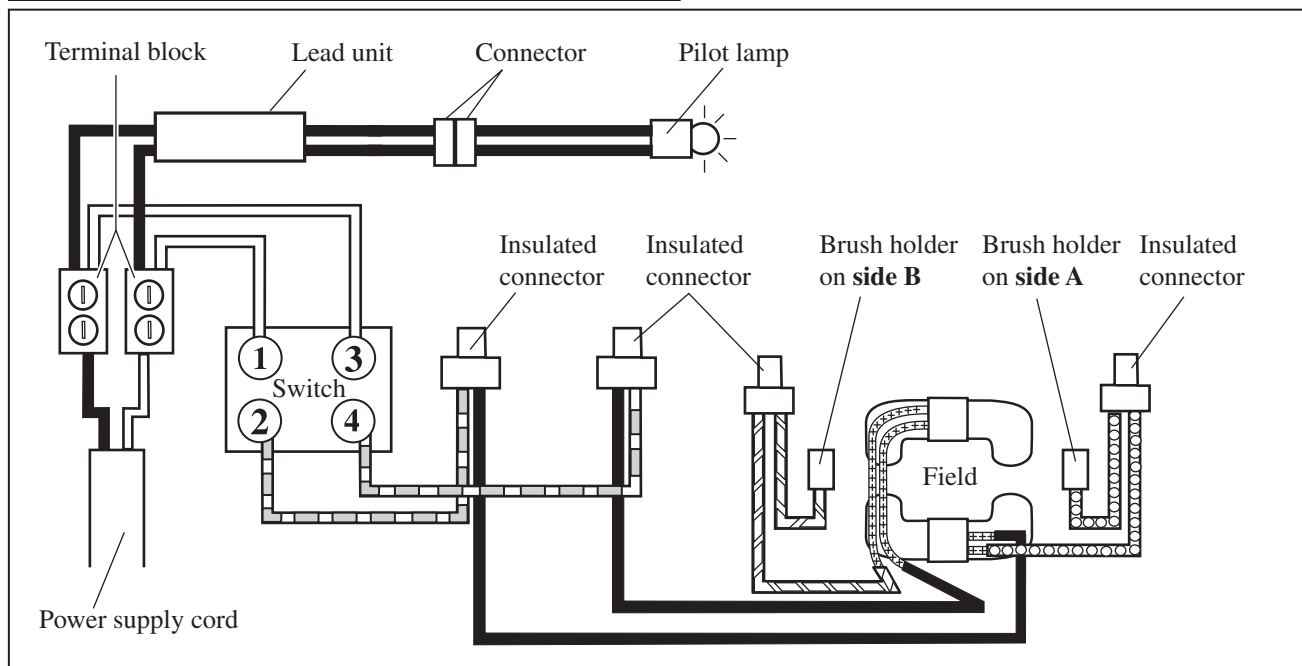
Color index of lead wires' sheath	
Black	
White	
Red	
Orange	
Purple	








**Countries That Require Noise Suppression Circuitry**

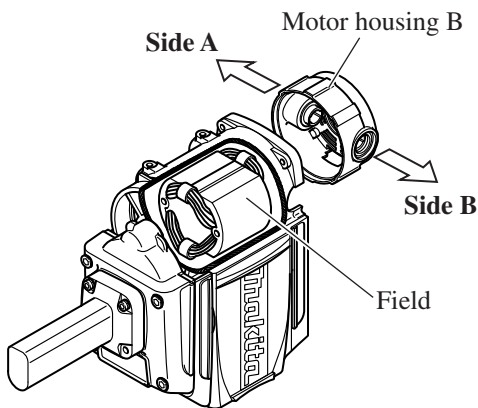


**USA, Canada, Panama, Mexico, Cyprus, Korea**

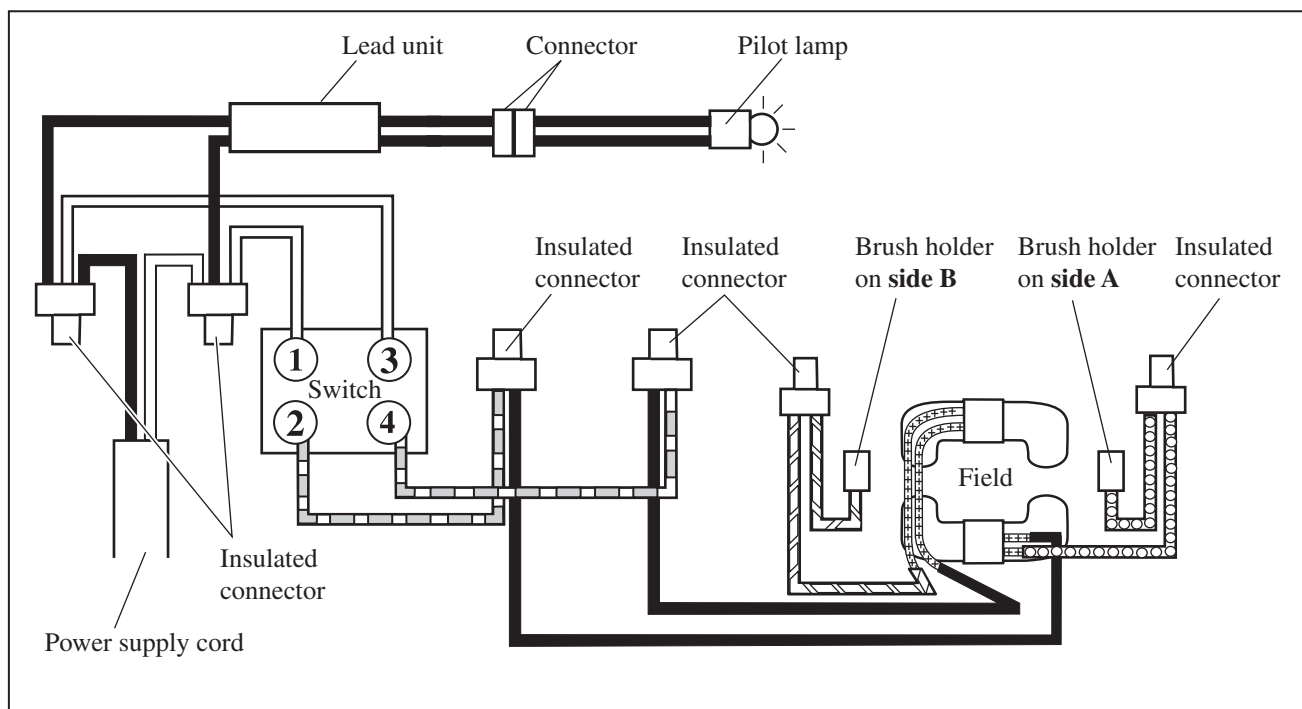


► **Circuit diagram**

Color index of lead wires' sheath	
Black	
White	
Red	
Orange	
Purple	



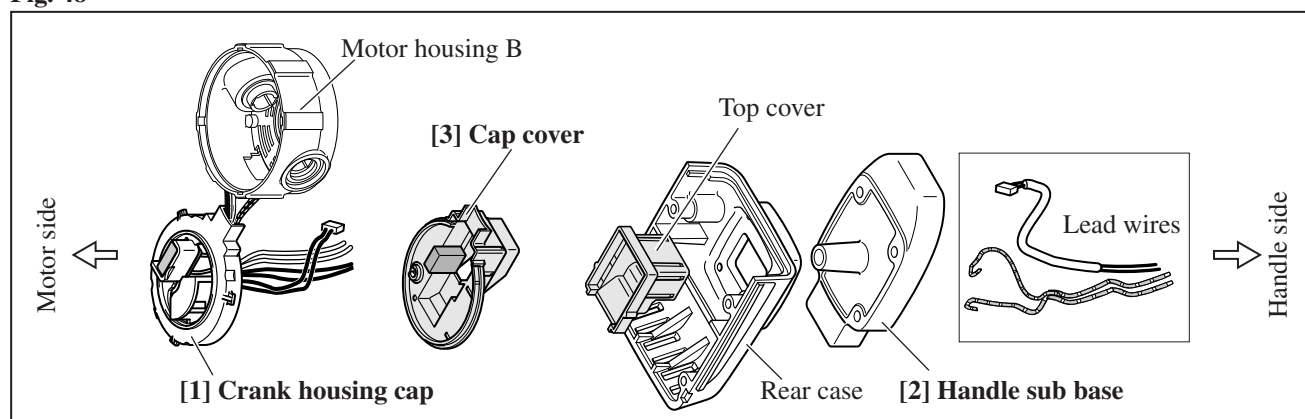
**Other Countries**



## ► Wiring diagram

We are explaining the wiring in three sections. (Fig. 48)

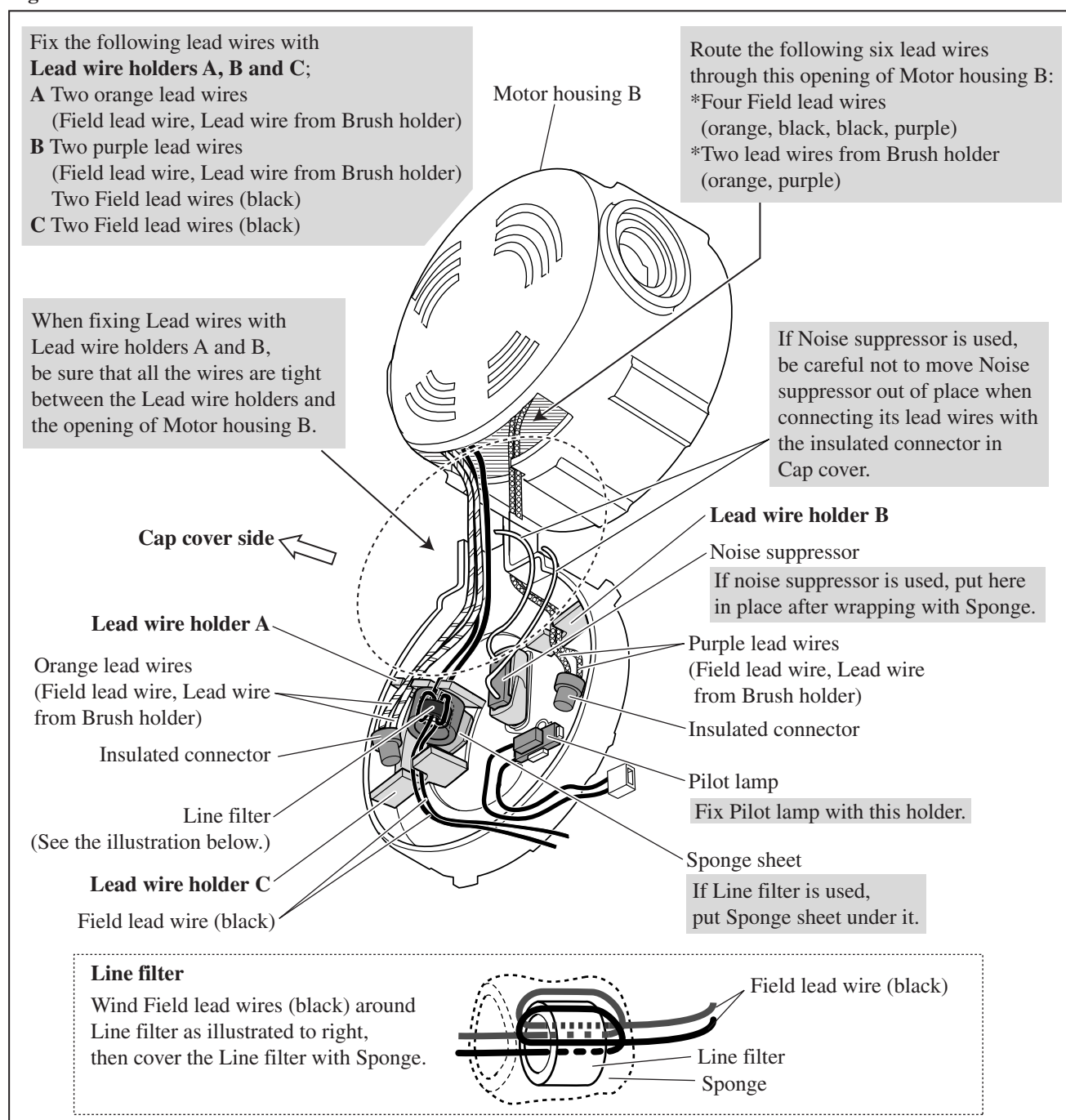
Fig. 48



### [1] Wiring in Crank Housing Cap

**Note:** Illustrated below in Fig. 49 is Crank housing cap viewed from Cap cover side.

Fig. 49



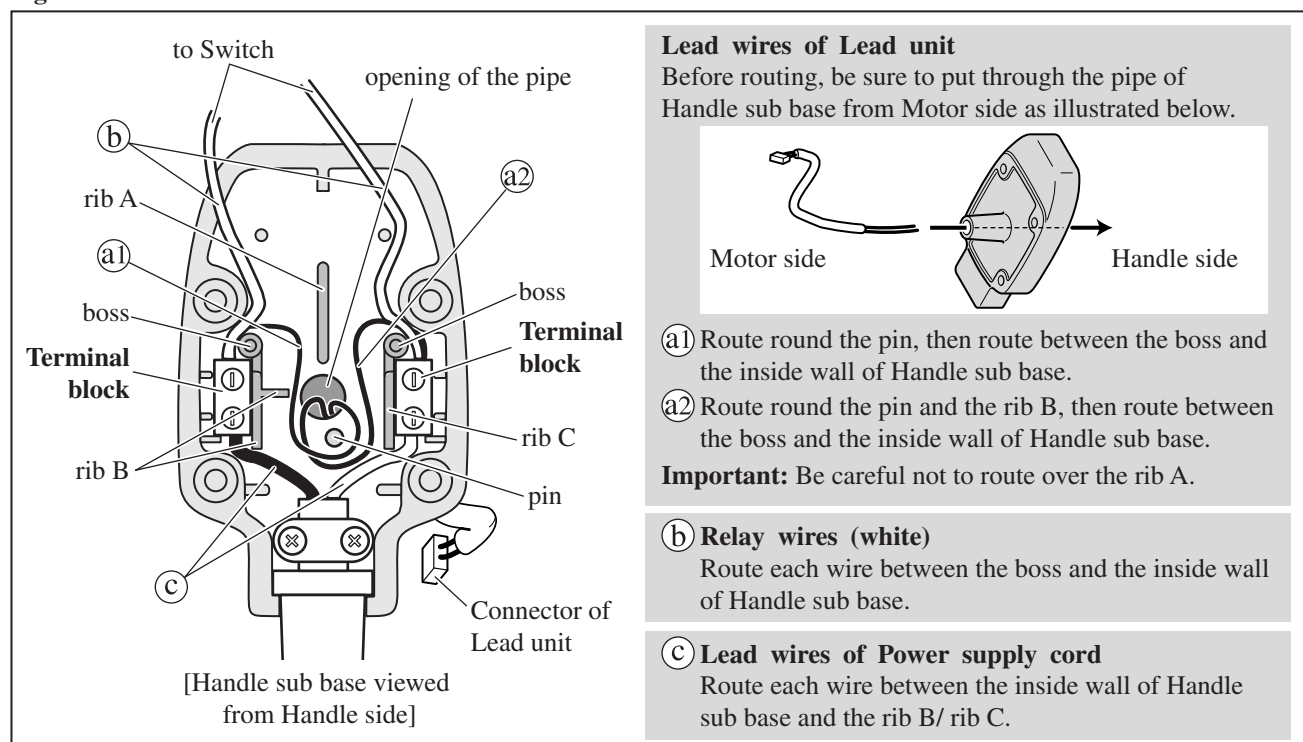
## ► Wiring diagram

### [2] Wiring in Handle Sub Base

#### When Using Terminal Block

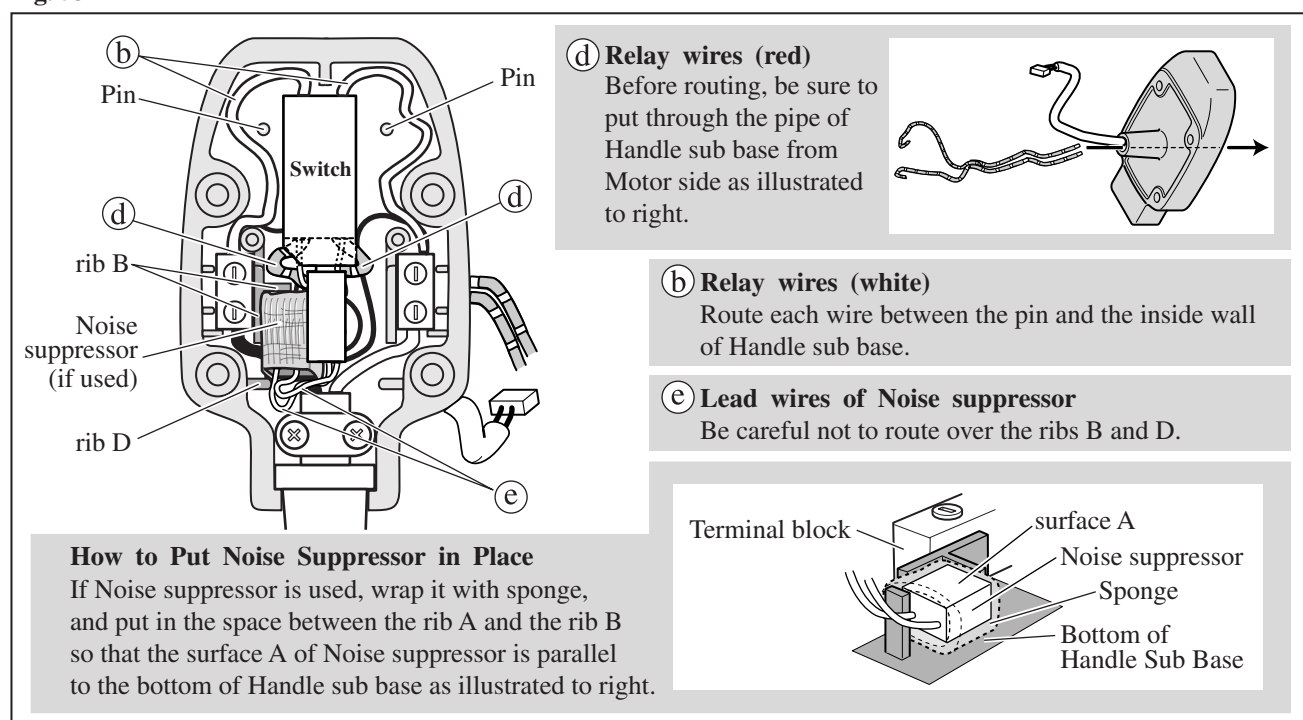
1) **Before installing Switch**, connect the lead wires with Terminal blocks as illustrated in **Fig. 52**.

**Fig. 52**



2) **After installing Switch**, connect the lead wires with Switch as illustrated in **Fig. 53**.

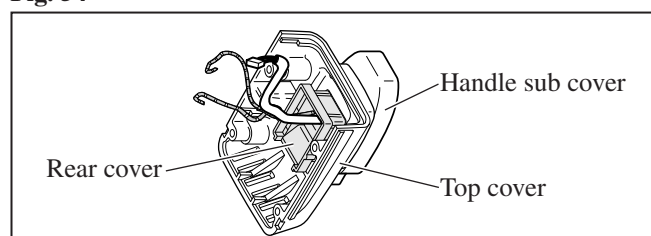
**Fig. 53**



3) After finishing the wiring in Sub handle base, route the following lead wires through the opening of Top cover and Rear cover as illustrated in **Fig. 54**:

- Lead wires of Lead unit
- Relay wires (red)

**Fig. 54**





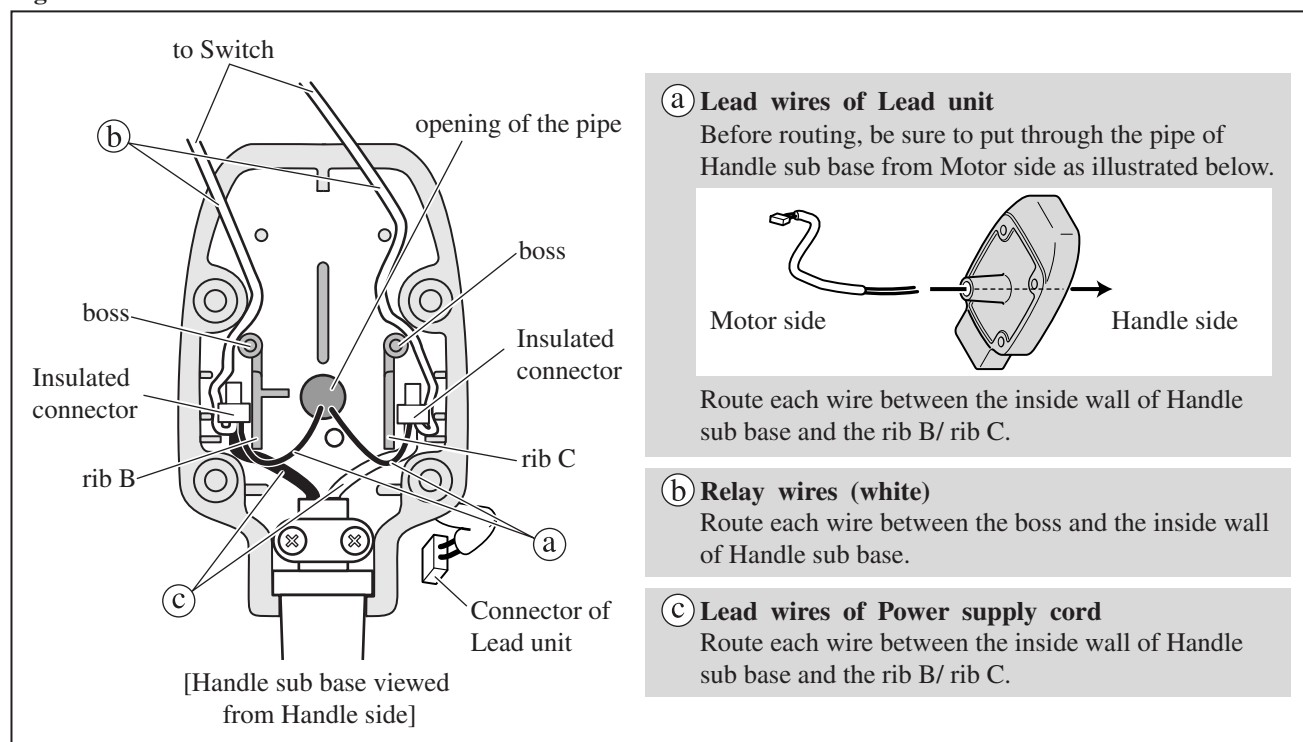
## ► Wiring diagram

### [2] Wiring in Handle Sub Base

#### When Not Using Terminal Block

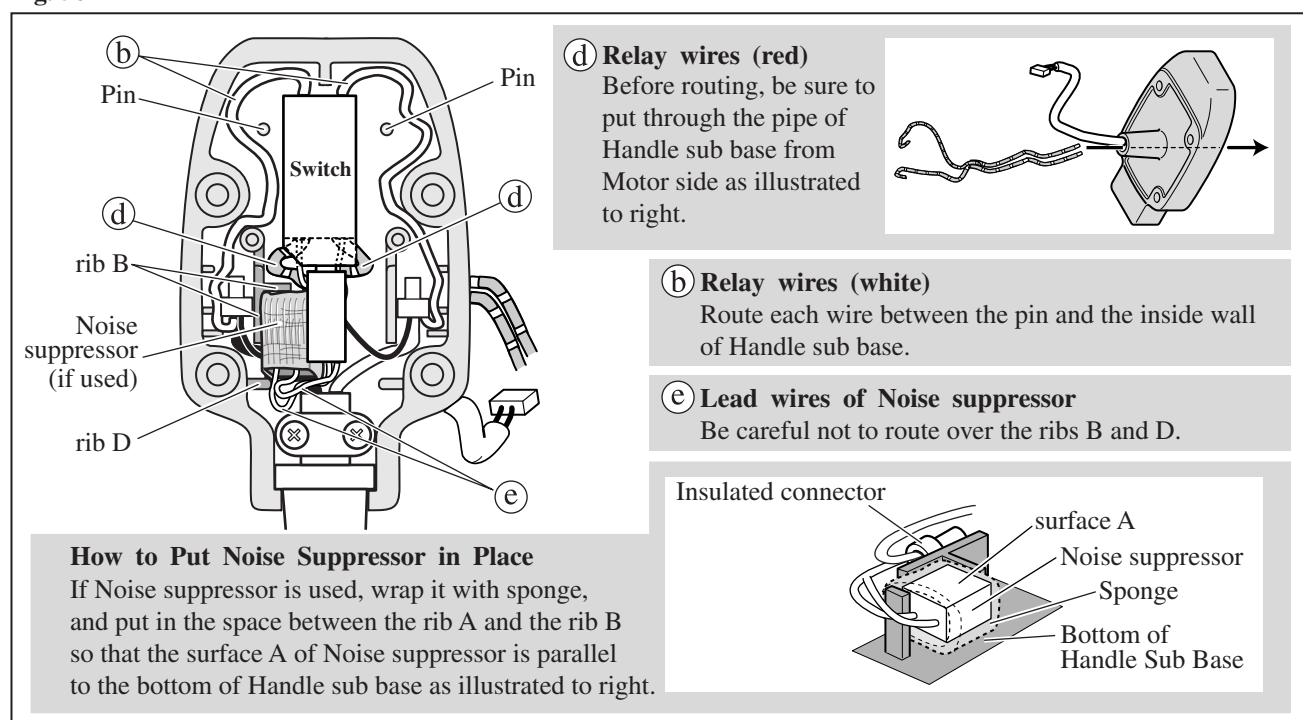
1) Before installing Switch, connect the lead wires with Insulated connectors as illustrated in Fig. 55.

Fig. 55



2) After installing Switch, connect the lead wires with Switch as illustrated in Fig. 56.

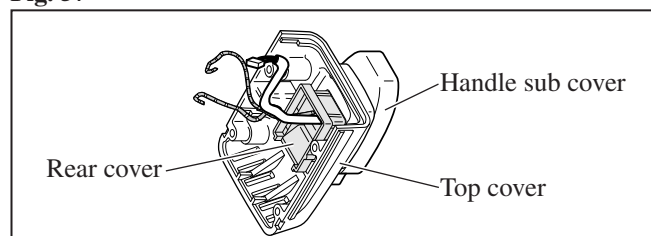
Fig. 56



3) After finishing the wiring in Sub handle base, route the following lead wires through the opening of Top cover and Rear cover as illustrated in Fig. 57:

- Lead wires of Lead unit
- Relay wires (red)

Fig. 57

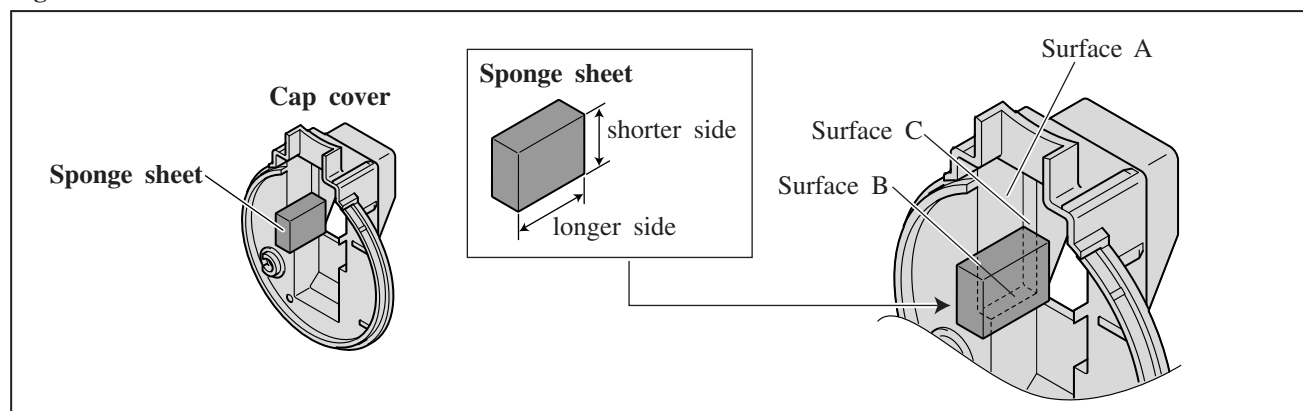


## ▶ Wiring diagram

### [2] Wiring in Cap Cover

- 1) First, if Noise suppressor is used, in order to protect lead wires, stick Sponge sheet to the surface A of Cap cover so that the longer side of Sponge sheet contacts the surface B of Cap cover and the shorter side contacts the surface C. (Fig. 58)

Fig. 58



- 2) Then connect the lead wires as illustrated in Fig. 59.

Fig. 59

